

TR Wireless Crane Scales

General Specifications

- Display 22mm LCD display (TR-I), 15mm LCD display (TR-II)
- Capacities 3t~30t
- Keyboard 6 keys (Mechanical switch)-TR-I, 60 keys (Mechanical switch)-TR-II
- Housing Plated steel housing, ABS indicator
- Max. Divisions 3,000d
- ADC Sigma delta
- ADC update $\leq 1/10$ second
- Operating Temp. $0^{\circ}\text{C} \sim +40^{\circ}\text{C}$
- Power Crane scale: rechargeable battery 6V/4Ah;
Indicator (TR-I): NI-MH battery (1.2V/2000mAh x 6)
Indicator (TR-II): 100VAC to 250VAC (variable)



- Applications: 1. Weighing unit conversion 2. Display lock 3. Change division
- SGS 500% safety approval
- Internal rechargeable battery, up to 40 hours (without backlight)-TR-I
- RS-232 standard (TR-II)



TR Wireless Crane Scales

Model Name	Capacity	Readability	Division	Approx. weight	Approval
TR-I-3t	3t	1kg	3,000d	30kg	CE
TR-I-5t	5t	2kg	2,500d	47kg	CE
TR-I-10t	10t	5kg	2,000d	55kg	CE
TR-I-15t	15t	5kg	3,000d	75kg	CE
TR-I-20t	20t	10kg	2,000d	79kg	CE
TR-I-30t	30t	10kg	3,000d	127kg	CE
TR-II-3t	3t	1kg	3,000d	30kg	CE
TR-II-5t	5t	2kg	2,500d	47kg	CE
TR-II-10t	10t	5kg	2,000d	55kg	CE
TR-II-15t	15t	5kg	3,000d	75kg	CE
TR-II-20t	20t	10kg	2,000d	79kg	CE
TR-II-30t	30t	10kg	3,000d	127kg	CE

Dimensions(mm)

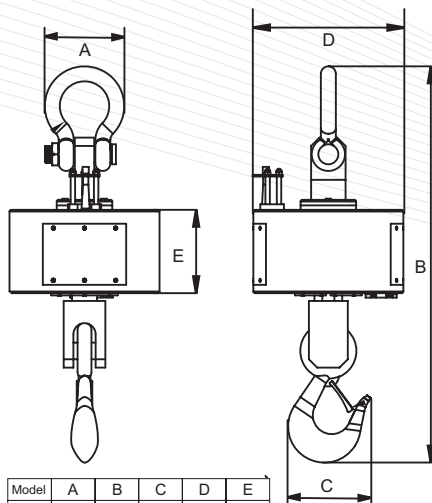

Model	A	B	C	D	E
3T	135	650	130	280	145
5T	140	760	160	285	150
10T	190	870	180	290	170
15T	190	950	210	320	198
20T	225	960	270	320	160
30T	253	1160	340	320	190