

MECHANICAL

Model 235 6M

Compact and robust, 150 mm diameter dial housed in the traditional metal case. Accurate to one part in 250 with up to 15% zero adjustment. Supplied with top and bottom hooks

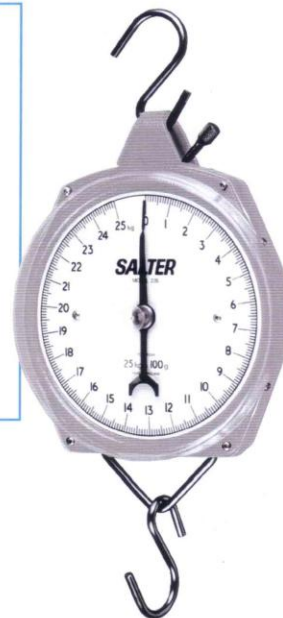
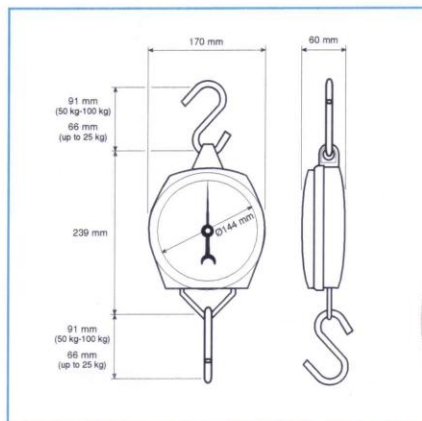

Metric

- 5 kg x 20 g
- 10 kg x 50 g
- 25 kg x 100 g
- 50 kg x 200 g
- 100 kg x 500 g

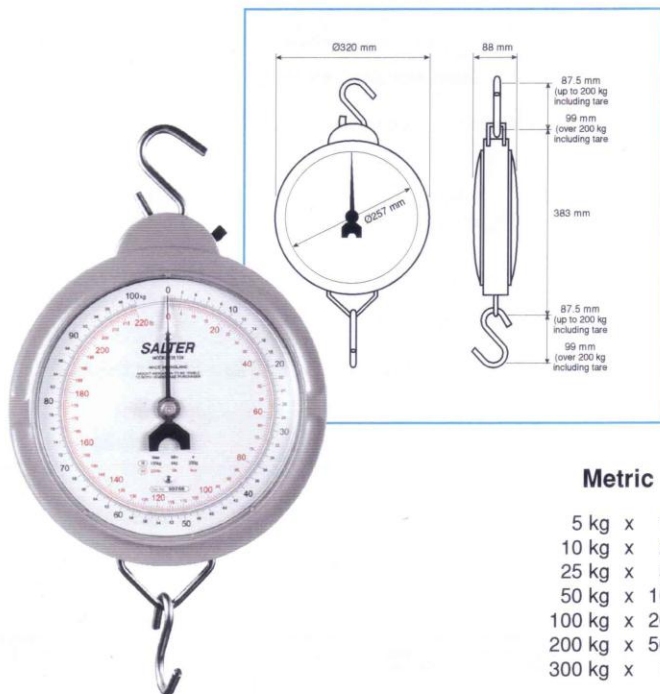

Model 235 10X (Trade & Non-Trade)

Heavy duty suspended scale, Eu trade approved up to 100 kg. 254 mm diameter easy to read dial housed in a robust grey die cast casing with low friction bearings providing positive movement to give maximum sensitivity. Accurate up to one part in 1000 trade, One part in 500, non-trade. Supplied with top and bottom hooks as standard. Double dial versions available, metric only, or up to 50 kg, dual marked.

Option

- Swivel bottom hook.
- Double lipped scoop (5 kg/10 kg only)

Metric

- 5 kg x 10 g
- 10 kg x 20 g
- 25 kg x 50 g
- 50 kg x 100 g
- 100 kg x 200 g
- 200 kg x 500 g
- 300 kg x 1 kg

