

Features

- Weighing application: 1. Check weighing 2. Simple counting 3. Animal weighing 4. Units conversion
- Build in rechargeable battery providing up to 70 hours of continuous use (without backlight)
- RS232 interface for connecting to computer and other optional peripheral devices (RS232 cable optional)

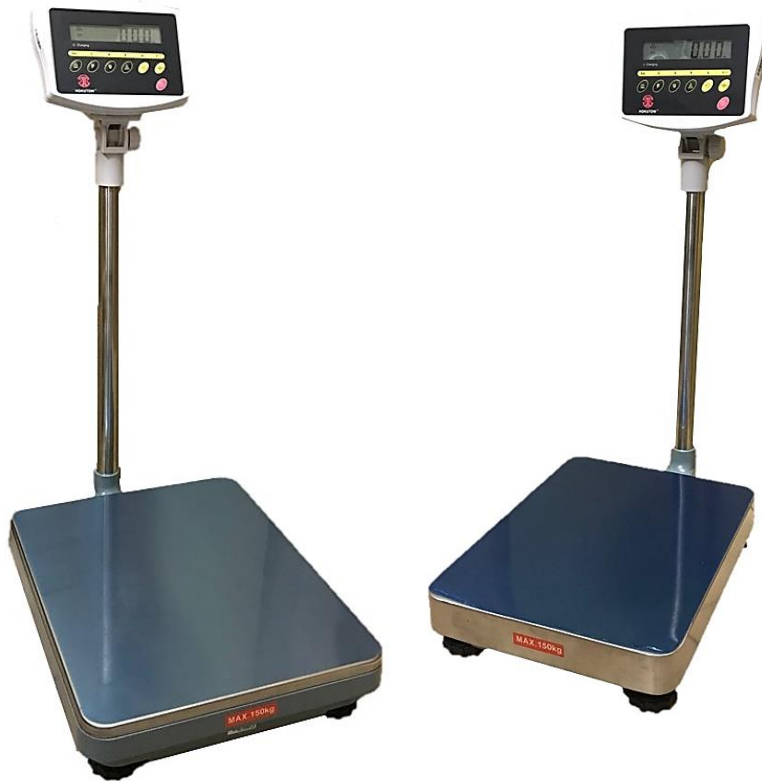

General specifications

- Capacities 60 kg ~ 600kg
- Display 24mm digit LCD display, with white LED backlight
- Keyboard 7 keys (Membrane keyboard)
- Housing ABS plastic indicator
- Max. Divisions 3,000e; 15,000d
- Load cell excitation voltage 5V/150mA
- ADC Sigma delta
- ADC update $\leq 1/10$ second
- Operating temperature 0 °C ~ 40 °C
- Power AC adaptor (12V/500mA), rechargeable battery (6V/4Ah)

Dimensions (mm)

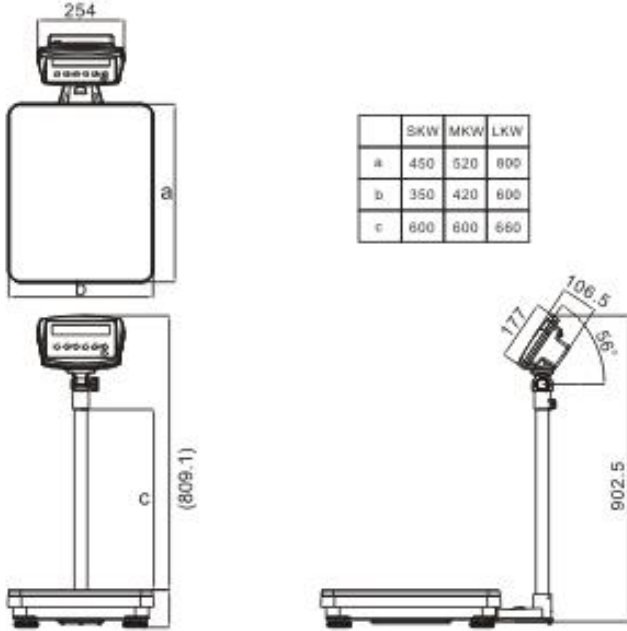

Print out sample (based on receipt printer)



Specifications

Model Name	SKWT-60	SKWT-150	MKWT-150	MKWT-300	LKWT-600
Capacity	60 kg	150 kg	150 kg	300 kg	600 kg
Readability	10 g	20 g	20 g	50 g	100 g
Platform size (mm)	450 x 350		520 x 420		800 x 600
Display	24mm LCD display with backlight				
Operation Temperature	0 °C to 40 °C				
Power	AC adaptor (12V / 500mA), Rechargeable battery (6V / 4Ah)				
Gross Weight	17kg	17kg	19kg	19kg	66kg

Optional accessories

