

DS-166 Series

Electronic Platform Scales

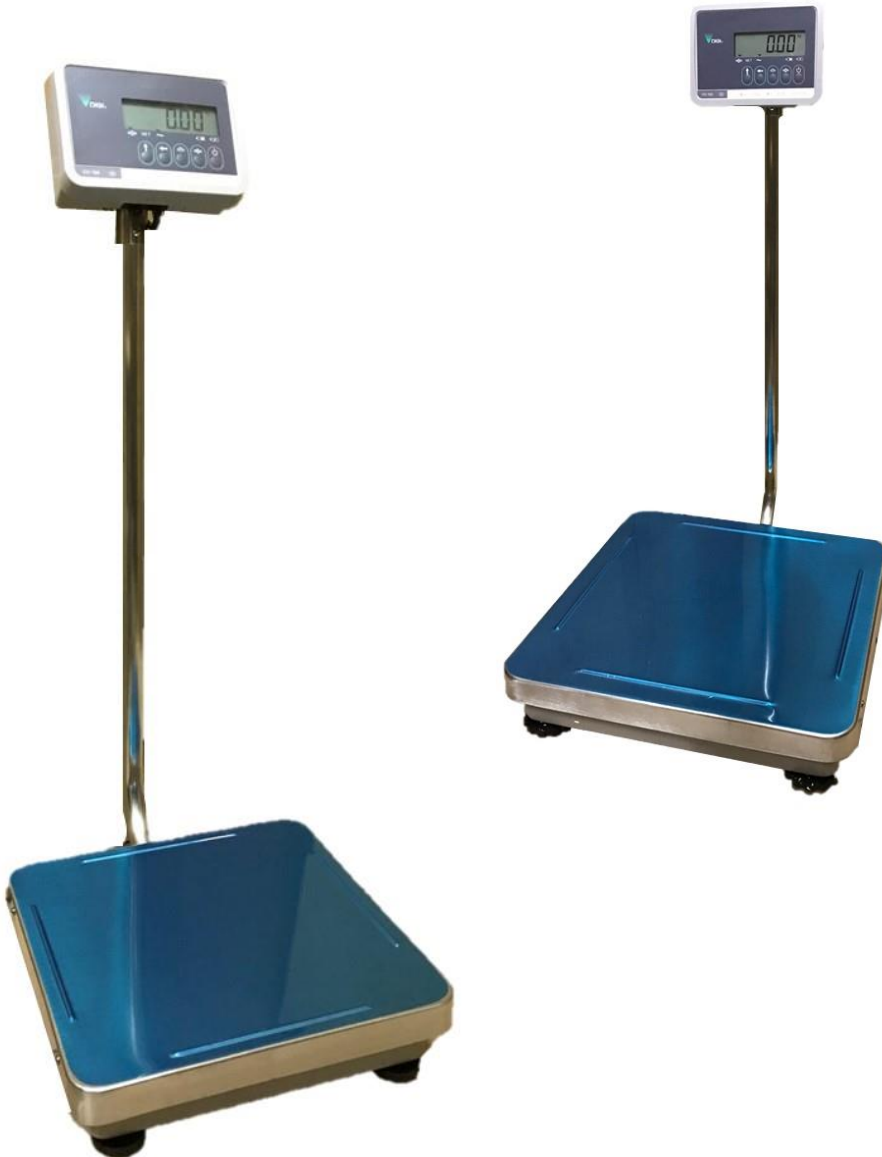

For speedy and accurate weighing operation plus linked to PC via RS-232 I/F



DS-166 assists accurate and speedy weighing operation with the following useful features.

- Bright LCD display with 1/150,000 resolution
- One touch/digital tare subtraction
- Zero recall function
- Two set points for HIGH/OK/LOW
- RS-232C interface link to PC

DS-166 Series

Electronic Platform Scales



Models	DS-166AP			DS-166BP	
Capacity x Readability	30kg x 5g	60kg x 10g	150kg x 20g	150kg x 20g	300kg x 50g
Platform size (W) x (D) x (H)mm	380 x 380 x 90			480 x 480 x 96	
Leveling Component	Externally visible level bubble and adjustable leveling feet				
Interface	Bi-directional RS232				

Specifications

Analogue section

Input sensitivity	0.4mV/V -4mV/V
Load cell excitation	5VDC, 60mA(max)
Speed of A/D conversion	20 times/sec – 30 times/sec
Number of load cells	1 load cell (350Ω)

Digital section

Display	6 digits
Display division	1, 2.5
Decimal point location	6 positions 0,00000 thru 000000
Indicator marks	“ZERO”, “NET”, “STABLE”, “LOW BATTERY”, “CHARGING”, “kg”, “lb”, “HIGH”, “OK” and “LOW”

General

Power source	AC 240/230/220V, 117/110V (+10%, -15%)(factory preset), Rechargeable battery (6V 1.2Ah)
Power consumption	18W(AC), 0.7W(battery)
Operating temperature	-10°C to 40°C
Operating humidity	15 – 18% RH

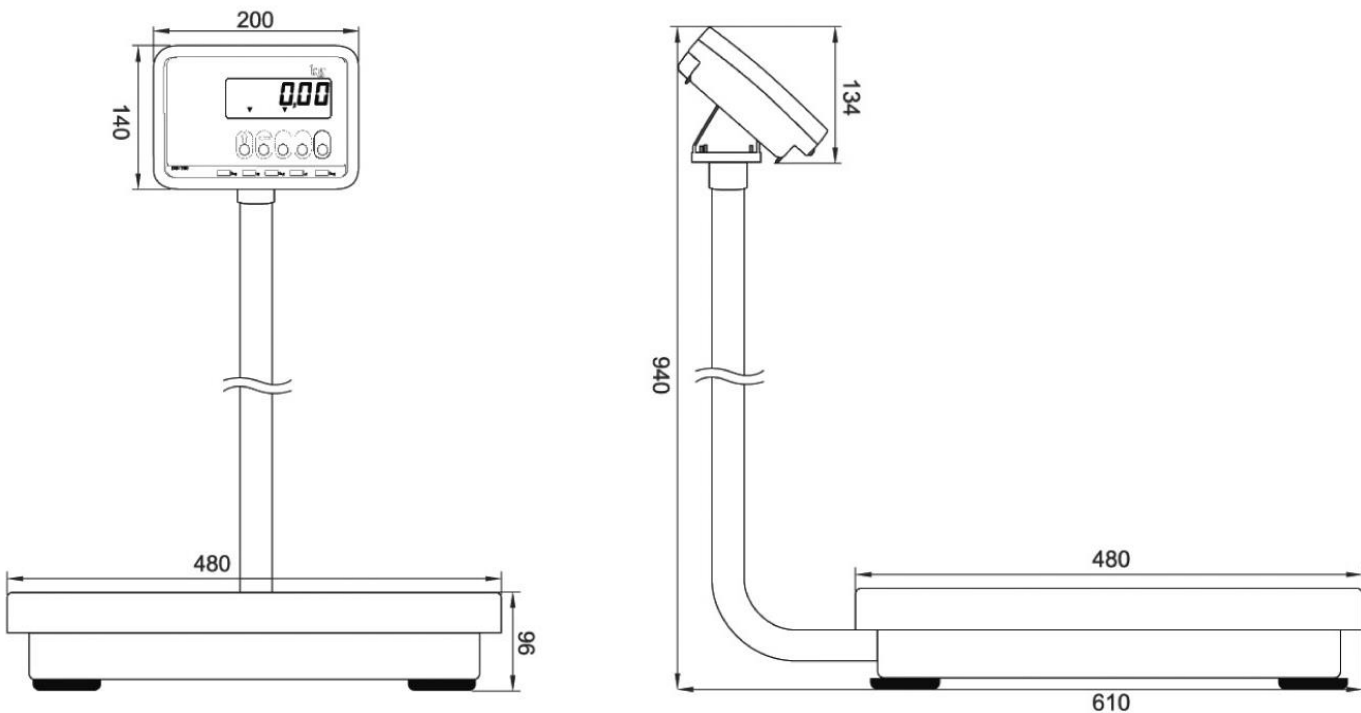

Above dimension refers only to model DS-166BP